

# ECO VIMEC HOMELIFT

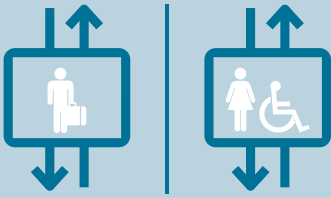

Electric, ecological, exclusive.

**VIMEC**



## ECOVimec

### Technology

Low energy consumption  
Noiseless, class-leading  
Carrying capacity of 400 kg, without counterweight  
MRL Machine RoomLess

### Safety

In case of power failure, back to the floor automatically  
Infrared barriers  
Communication device inside the cabin

### Ecologic

Without hydraulic oil  
Manufacturing process with waste materials for recycling



## Customised

Many personalisation options to suit all tastes. Suitable for both indoor and outdoor installation. Quick to install with no invasive building works

## Design

Vimec's focus on styling is expressed through the shapes and materials chosen to express wellbeing attention to details, and a love of our work





## Quality

In Vimec products, quality means substance: reliability, quiet operation, user-friendly technology

The ECOVimec lift fits into any domestic context with discretion and elegance. It is a 100% Italian product, and every installation clearly reflects its membership of the world-famous Italian design and styling tradition.



## Experience

Vimec is the market leader, and has been designing and building tailor-made installations to improve quality of life for all access needs, both in the home and in public buildings, since 1982.





# Cabin colours

Eco Vimec offers you many customisation options, starting from the walls of the cabin, available in different finishings and colours, through the platforms, in fine materials in a variety of shades. A wide choice of structure finishings are available to provide the best match with the surrounding colours and environment.

## Cabin Walls Colours

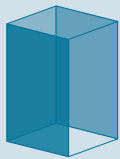

### COLOR SERIES



Grey standard



Beige standard



Blue standard



Red standard



Special RAL colour

### GLASS SERIES



Transparent



Smoked

### WOOD SERIES



Standard Maple



Standard Cherry wood

### STAINLESS SERIES



Polished Linen

## Cabin Platform Colours

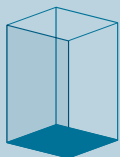

### RUBBER SERIES



Grey with stamps

### SAFESTEP SERIES



Light grey



Dark grey



Red

### WOOD SERIES

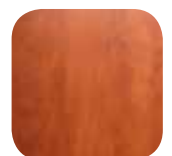

Wild Pear

## Supporting Structures

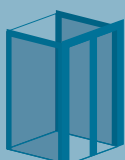

### SUPPORTING STRUCTURES



VIMEC 7040 standard



RAL 1013 light ivory



RAL 9023 pearl dark grey



Special RAL colour



# Accessories

Choosing your ECO VIMEC's materials, colours and special comforts will be a thrill of experience every time you enter the cabin.

## ★ Doors



Two speed fully automatic telescopic and landing doors (fire rated version available)

## ★ Handles



Infrared sensors all around the perimeter for entry/exit from the cabin, to guarantee full safety.



## Alternative colours



Stainless



Special Ral



Three speed automatic telescopic and landing doors (fire rated version available)



Double hinged, in glass, for an elegant, stylish effect



Panoramic, in aluminium; lightness at hand



Blind hollow veneered



Hollow veneered with viewing



# ★ Control Panels

## On-board control Panel



- A) LCD display with travel indicator
- B) Telephone speaker/auto dialer
- C) Dark blue backlit buttons with Braille
- D) I-button, for electronic access control
- E) Alarm button

## Floor control panel

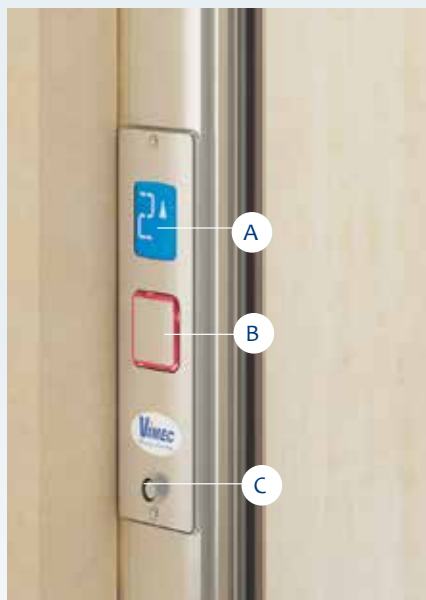

- A) LCD display with travel indicator
- B) Call button: green when lift is free, red when busy
- C) I-button, for electronic access Control

The technological content and choice finishes make the cabin a pleasant place to be, with comfort and safety, at all times.

# ★ Cabin lighting

## LED bar standard



## Starry sky



# ECOVimec

## The right choice, the choice of taste

The homelift that increases the convenience and prestige of your home and the installation sites.

ECOVimec is intended for everyone who gives priority to their own wellbeing and that of their family. Comfortable and safe, it fits into any context, guaranteeing your home a prestige installation that will increase its value.

### Versatile

ECOVimec lift gives added value to all homes through simple tailor-made installations, both indoors and out. Available in versions from two to five floors, it is an ideal system both for renovation projects and for new buildings: no masonry works are required.

### Customisable

You and your home deserve a lift which is tailored to suit you not only in its functions but also in its design and personalised finishes; the colours and trims available ensure your Easy Living is just as you want it, the perfect match for its context and your taste.

### Convenient, effortless

Quiet and discreet, it is absolutely convenient even for transporting the shopping, child buggies, and any other heavy or bulky item from one floor to another within the home. With the ECOVimec, getting around the house could not be easier.

### Reliable

The Vimec technology guarantees you a product at the state of the art from every point of view.





## ECOVimec with structure

The ECOVimec lift has state of the art structures in terms of strength, versatility and design.

These structures can be customised with different types of glass panelling to suit installations of all kinds, with tailor-made versions and installations even in particularly difficult contexts.

A Vimec outdoor lift never requires invasive building works: installation is completed quickly and with great care, thanks to a network of skilled installers always up to date with the latest products and techniques.







## Features

The ECOVimec technical package has parameters and functional requirements of the highest order.

ECOVimec is a unique elevator:

- Environmentally friendly-electric lift compliant to the Machinery Directive 42/2006
- In the event of a power failure automatically returning to the floor
- Without counterweight
- MRL Machine RoomLess



## Technical data

Capacity	up to 400 kg
----------	--------------

Maximum travel	5 stops (about 14,6m)
----------------	-----------------------

Speed	0,15 m/sec.
-------	-------------

- Safety stop in the pit with electric monitoring and visual flashing alarm with manual reset
- Mechanical safety lock in the headroom with surveillance (electric lock)
- O.S.G. Over Speed Governor: a **speed limiter**
- Loose control drive belts with electric monitoring and shutdown
- O.L.C. **Over Load Control**: Lock and load control equipment
- In case of power failure, electric emergency operation (Battery 36-Volt)
- Easy maintenance directly inside the cabin by moving the control panel

### INSIDE THE CABIN:

- Infrared barriers on each side of entry and in the absence of walls
- Device of communication with outside the cabin
- Over Load indicator
- 50 x 50 mm buttons with mechanical shutter and indication of the floor in addition to standard Braille
- On board controls height compliant to EN81-41
- Illuminated buttons (with color identification of the function)
- Emergency Button
- "Energy saving" LED Bar lights
- On board push-button panel with dead-man's controls-always equipped with infrared photocells barriers
- "Single Touch" operation (universal manoeuvre) with walls and door in the cabin

### OPTIONS:

- I-button (electronic key) to manage independent accesses
- Voice announcer to the incoming floor
- Gong to the incoming floor
- Auto dialer with 5 numbers in memory
- Display in the car
- Display on the floor control panel
- Handrail fitted to cabin wall for use in public places and for people with disabilities
- Sliding doors on cabin and at all floors
- Power door operator for swing doors
- Fire rated doors
- Horizontal Mirror
- Vertical mirror

### GENERAL FEATURES

- Drive system and **at-the-ground control**
- Belt drive
- Drive motor 1.5 kW three-phase 220 V 50 Hz
- Electric Traction
- **Soft start/stop** system
- Voltage supply 24 V DC
- Fire alarm return to safe floor
- Mechanical key enabling on-board keypad
- No. 6 accesses maximum
- No. 2 accesses to the floor maximum
- Electrical Safety Locks
- On floor controls with "Simple touch"
- 120 mm pit - 140 mm with supporting structure
- Technical Dimensions (engine, belts) 310 mm
- Headroom minimum standard 2450 mm
- Headroom with cabin door minimum 2600 mm
- Platform sizes available:
- 2 Standard: 1400 x 1100-1250 x 1000
- Special sizes available upon request

### STANDARD CONFIGURATION

- Cabin with "color series" grey walls (alternative choices: Beige, Red, Blue, Acero, Ciliegio)
- Platform "Rubber series" with grey stamps
- On-board and on the floor 50 mm buttons with Braille, without display
- "Energy Saving" with LED bar ceiling
- Hollow veneered doors with window - VIMEC 7040

Data are guideline and not binding. Vimec reserves the right to make any changes it considers appropriate.



# Dimensions and overall space requirements

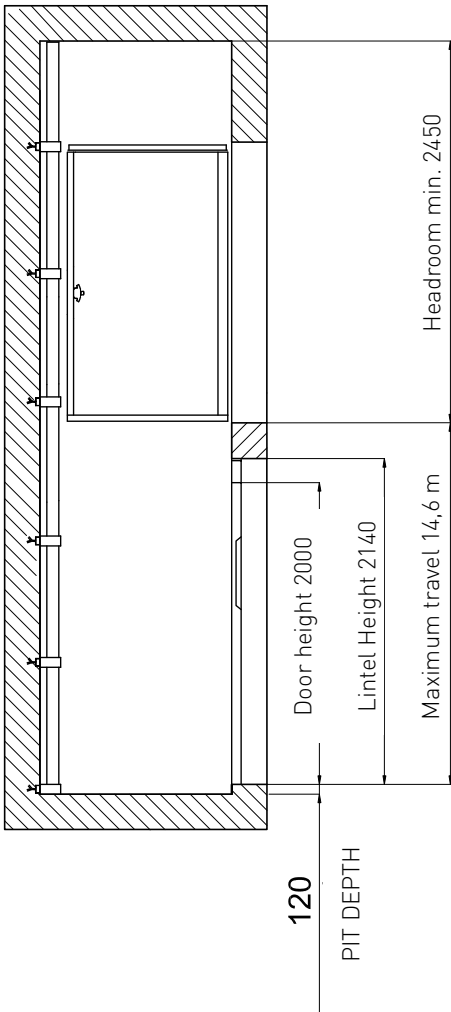

## Masonry Shaft

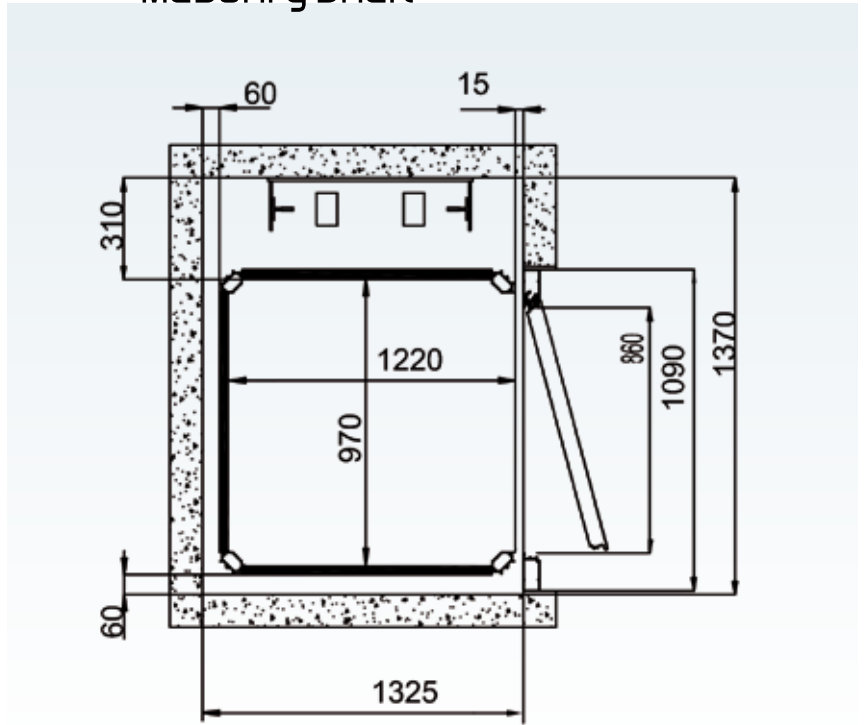

## Supporting Structure

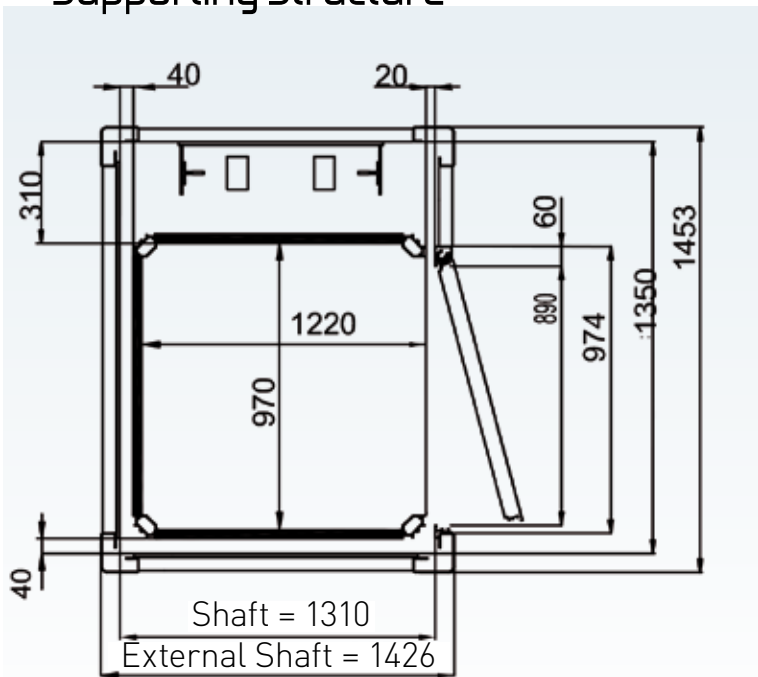

## With automatic telescopic doors

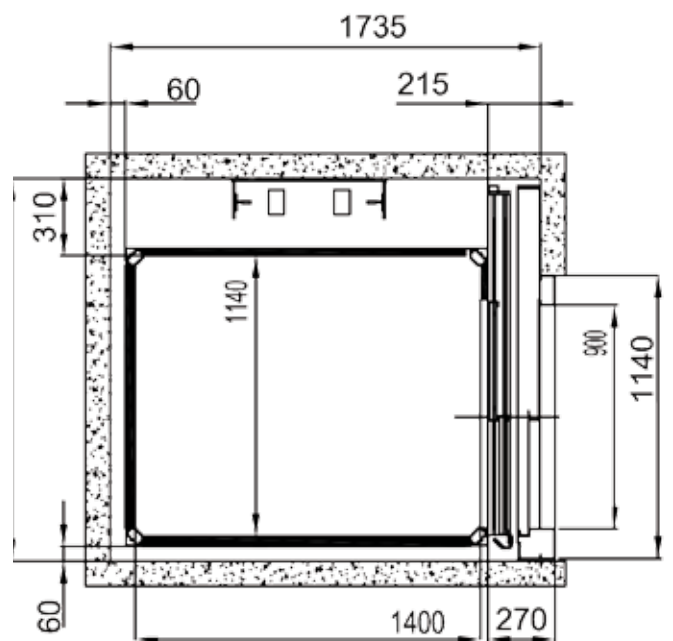



## ECOVimec - HL (Heavy Load) version

The ECOVimec - HL version (Heavy Load) has a higher load capacity: 500 kg

The finishes available for the version of HL are the same of ECOVimec; this solution is provided with a more powerful engine (2.2 kW) and the structure is stronger and more durable.

The platform sizes available for this model are: 1.460x1.170 mm and mm 1.300x1.030.

As an option, HL version can be supplied with a counterweight (150 Kg only), which makes it ideal for the most intensive uses.

### Dedicated to Extra EU markets

ECOVimec - HS (High Speed) Version

The ECOVimec - HS version (High Speed) has a higher speed (0,26 m/s) and a higher load capacity (500 kg)

The finishes available for the HS version are the same of ECOVimec; this solution is provided with a more powerful engine (2.2 kW) and the structure is stronger and more durable.

The platform sizes available for this model are: 1.460x1.170 mm and mm 1.300x1.030.

The HS version is always provided with the counterweight (150 Kg only)

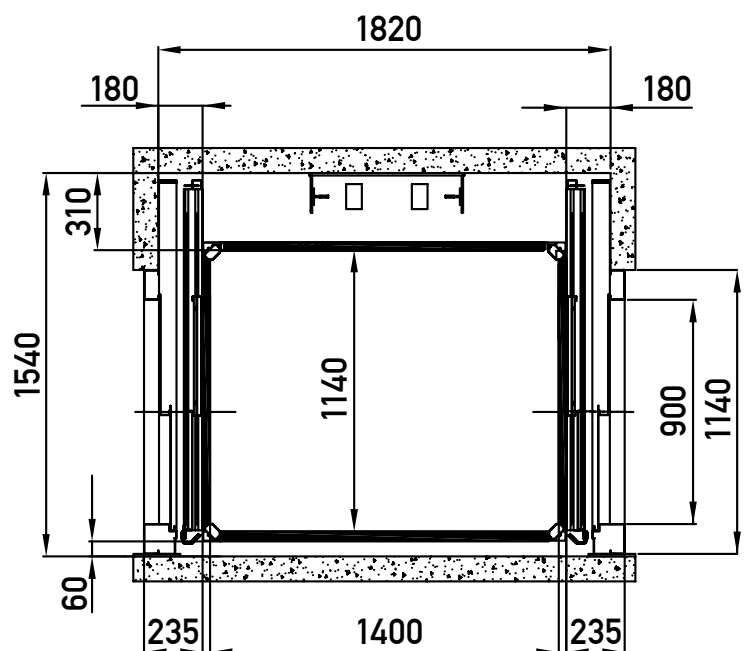



## VIMEC Range

Since 1982 Vimec designs, manufactures and installas customized solutions: home lifts and elevators, chairlifts and stairlifts, platform lifts and mobile stair climbers.

**More than 100,000 installations all over the world.**



### Guaranteed product

The Vimec elevator is guaranteed up to 24 months.

#### Vimec Accessibility LTD

Suite 56 Basepoint Business Centre - Caxton Close  
Andover, Hampshire - SP10 3FG  
Tel. +44 7780 574659  
export@vimec.biz  
[www.vimec.biz](http://www.vimec.biz)

#### Vimec abroad:

Madrid (Spain)  
Avignon (France)  
London (United Kingdom)  
Warsaw (Poland)



COMPANY  
WITH QUALITY SYSTEM  
CERTIFIED BY DNV  
**=UNI EN ISO 9001/2008=**

